

Installation
Operation
and
Maintenance
Instructions

Freezer
MS15FA



CONTENTS

Unpacking your freezer	3
Removing the packaging	3
Warranty Registration	3
Installing your freezer	4
Selecting the location	4
Cabinet Clearances	4
Leveling legs	4
Grounding method	5
Electrical Requirements	5
Handle Installation	5
Door Alignment	6
Using your freezer	7
Dimensions For MS15FA Solid Door	8
Recommended Rough in Opening Dimensions	8
For MS15FA Solid Door	8
Energy Saving Tips	9
Features	9
Care and Cleaning	10
Condenser air flow	10
Cabinet	10
Interior	10
Defrosting instructions	10
Troubleshooting your freezer	11
Obtaining Service	12
Commercial Product Warranty	13

Important Safety Instructions

Warnings and safety instructions appearing in this guide are not meant to cover all possible conditions and situations that may occur. Common sense, caution, and care must be exercised when installing, maintaining, or operating this appliance.

Recognize Safety Symbols, Words, and Labels.

CAUTION

CAUTION-Hazards or unsafe practices which could result in personal injury or property or product damage.

WARNING

WARNING-Hazards or unsafe practices which could result in personal injury.

NOTE

NOTE-Important information to make a problem free installation.

WARNING

State of California Proposition 65 Warning:
This product contains one or more chemicals known to the State of California to cause cancer.

WARNING

State of California Proposition 65 Warning:
This product contains one or more chemicals known to the State of California to cause birth defects or other reproductive harm..

UNPACKING YOUR FREEZER

Remove Packaging

Your freezer has been packed for shipment with all parts that could be damaged by movement securely fastened. Cut the banding material at the bottom of the carton, unfold the carton at the bottom, and remove the carton from the appliance. Remove the plastic bag, styrofoam corner posts, and any tape holding the door closed and internal components in place. The owners manual is shipped inside the unit in a plastic bag along with the warranty registration card.

Important

Keep your carton packaging until your unit has been thoroughly inspected and found to be in good condition. If there is damage, the packaging will be needed as proof of damage in transit. Afterwards please dispose of all items responsibly.

WARNING

WARNING - Dispose of the plastic bags which can be a suffocation hazard.

Note to Customer

This merchandise was carefully packed and thoroughly inspected before leaving our plant. Responsibility for its safe delivery was assumed by the retailer upon acceptance of the shipment. Claims for loss or damage sustained in transit must be made to the retailer.

DO NOT RETURN DAMAGED MERCHANDISE TO THE MANUFACTURER - FILE THE CLAIM WITH THE RETAILER.

NOTE

If the unit was shipped or has been laying on its back for any period of time allow the freezer to sit upright for a period of at least 24 hours before plugging in. This will assure oil returns to the compressor. Plugging the freezer in immediately may cause damage to internal parts.

Warranty Registration

It is important you send in your warranty registration card immediately after taking delivery of your freezer or you can register online at www.agamarvel.com.

The following information will be required when registering your unit.

Model Number
Serial Number
Date of Purchase
Dealer's name and address

The model number and serial number can be found on the serial plate which is located on the bottom face inside the cabinet.

WARNING

Help Prevent Tragedies

Child entrapment and suffocation are not problems of the past. Junked or abandoned freezers are still dangerous - even if they sit out for "just a few days".

If you are getting rid of your old freezer, please follow the instructions below to help prevent accidents.

Before you throw away your old freezer:

- Take off the doors or remove the drawers.
- Leave the shelves in place so children may not easily climb inside.

INSTALLING YOUR FREEZER

Select Location

The proper location will ensure peak performance of your appliance. We recommend a location where the unit will be out of direct sunlight and away from heat sources. To assure your product performs to specifications the recommended installation location temperature range is from 65 to 90°F (18 to 32°C).

Cabinet Clearance

Ventilation is required from the bottom front section of the unit. Keep this area open and clear of any obstructions. Adjacent cabinets and counter top can be installed around the unit as long as the grille and door access remain unobstructed.

Leveling Legs

Adjustable legs at the front and rear corners of the unit should be set so the unit is firmly positioned on the floor and level from side to side and front to back. The overall height of your Marvel freezer, depending on the model, may be adjusted from 24-1/8" (61.3cm) with the leveling legs turned in, and up to 25-1/8" (63.8cm) with the leveling legs extended.

To adjust the leveling legs, place the freezer on a solid surface and protect the floor beneath the legs to avoid scratching the floor. With the assistance of another person, lean the freezer back enough to access the front leveling legs and remove the weight. Raise or lower the legs to the required dimension by turning the legs. Repeat this process for the rear by tilting the freezer forward using caution to prevent the door from opening. On a level surface check the freezer for levelness and adjust accordingly.

The front grille (toe kick) screws may be loosened and adjusted to the desired height. When adjustment is complete tighten the two toe kick screws. (See Figure 2).

CAUTION

Front Grille

Do not obstruct the front grill. The openings within the front grill allow air to flow through the condenser heat exchanger. Restrictions to this air flow will result in increased energy usage and loss of cooling capacity. For this reason it is important this area to not be obstructed and the grill openings kept clean. AGA MARVEL does not recommend the use of custom made grills as air flow may be restricted because of inadequate openings. (See Figure 1).

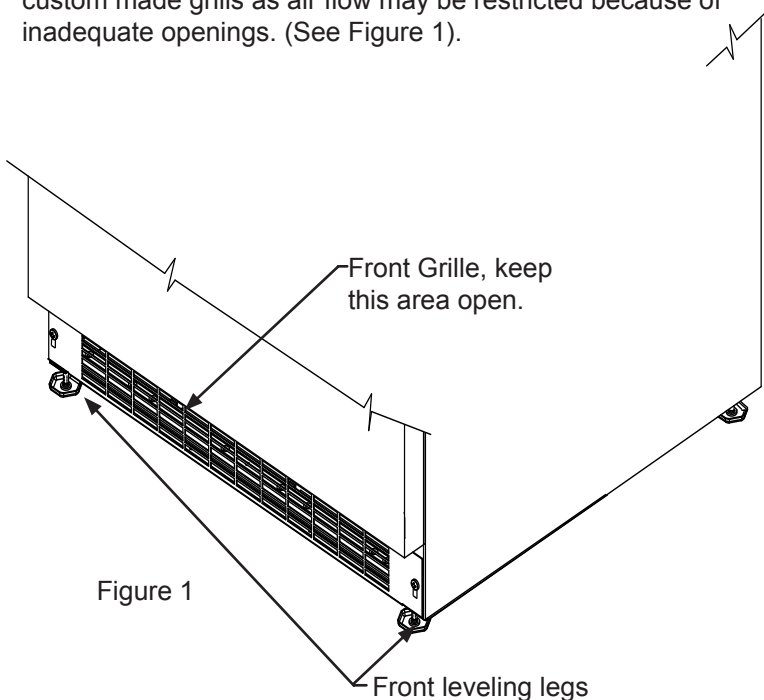

Figure 1

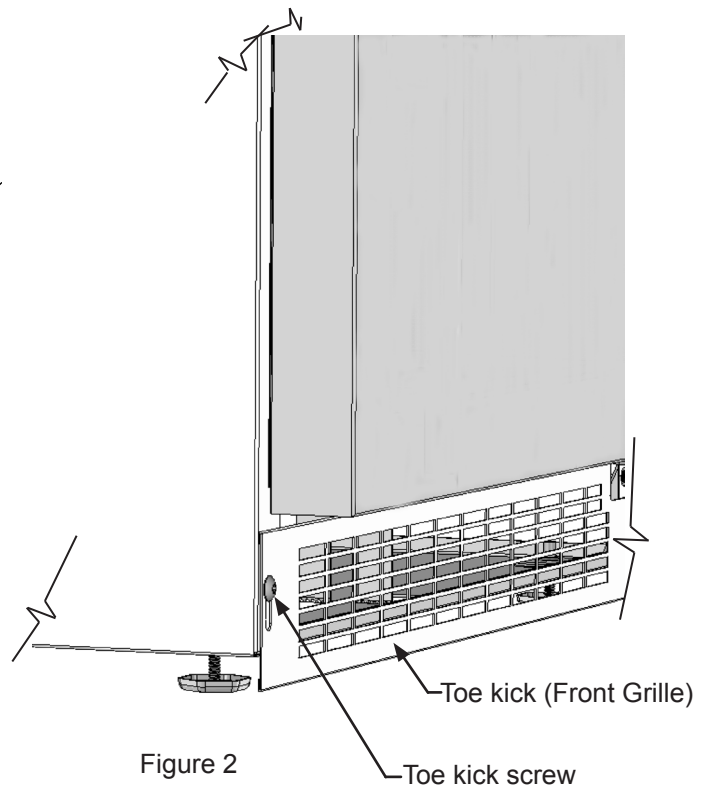

Figure 2

HANDLE INSTALLATION

CAUTION

- Do not splash or spray water from a hose on the freezer! Doing so may cause an electrical shock, which may result in severe injury or death.
- This unit should not, under any circumstances, be installed to an un-grounded electrical supply.

Grounding Method

This product is factory equipped with a power supply cord that has a three-pronged, grounded plug. It must be plugged into a mating grounding type receptacle in accordance with the National Electrical Code and applicable local codes and ordinances (see Figure 3). If the circuit does not have a grounding type receptacle, it is the responsibility and obligation of the customer to provide the proper power supply. The third ground prong should not, under any circumstances, be cut or removed.

Electrical Connection

A 115 volt, 15 amp dedicated circuit is required. A 3 prong grounded receptacle is required.

The unit must be installed according to your local building codes and ordinances.

CAUTION

Do not use an extension cord with this appliance.

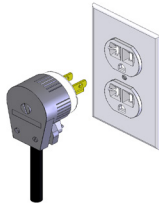

Figure 3

Handle Installation (Solid Door Models)

1. Remove the handle, (2) screws, and 5/32" allen wrench from the bag shipped inside the cabinet.
2. Locate handle opposite the hinges and secure in place using the (2) screws and the allen wrench. (See Figure 4).

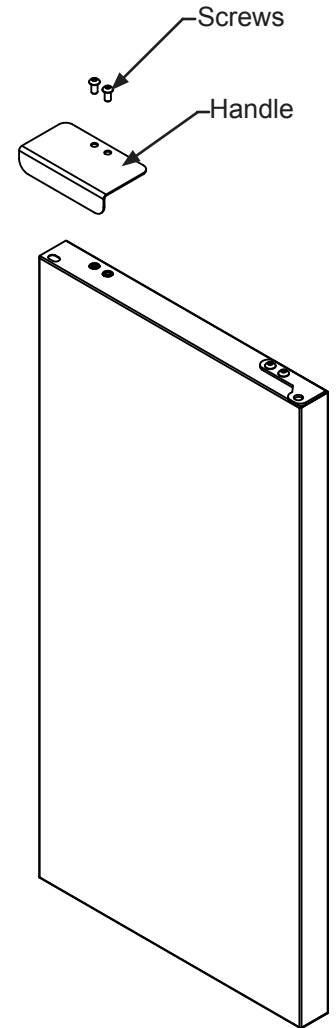

Figure 4
Right hand hinged door shown

Door Reversal

It is possible to reverse the door (change from right hand swing to left hand swing or vice versa) if you wish. To do so it will be necessary to order one of the service kits below.

Hinge Color	Door Color	Right Hand	Left Hand
Chrome	White	42247639	42247640

DOOR ALIGNMENT

Door Alignment Procedure

The door should be parallel to the sides and top of the freezer. If alignment is necessary the door may be adjusted by loosening the 2 screws which secure the hinge adapter brackets on the top and bottom of the door and adjusting the door side to side. Use a 5/32" allen wrench for this procedure. (See Figure 5 below). When finished aligning the door, tighten the screws securely.

Hinge adapter bracket located on the top and bottom of the door.

Remove top hinge pin to remove the door.

9/32"
(7.1mm)

Door must be parallel to top and sides of freezer.

Figure 5

NOTE

For the door to close properly, it is necessary to maintain a minimum space of 9/32" (7mm) between the door and cabinet flange (See Figure 5). This space can be adjusted by adjusting the top and bottom hinge adapter brackets.

USING YOUR FREEZER

Turning on the freezer

After setting the freezer in place, leveling (see page 4), plug the power cord into the wall receptacle. The freezer should start after plugging in. The temperature control is factory preset to a mid range setting. Allow the freezer to run for 24 hours so the interior temperature stabilizes. If you wish to adjust the interior temperature use a small bladed screwdriver pushed through the right hand side of the grille to turn the temperature control shaft. Turning it clockwise will make the unit colder. Turning it counterclockwise will make it warmer. Turning it counterclockwise until it stops will shut off the compressor and fan motor.

CAUTION

Should you turn off your control, allow at least five (5) minutes before restarting in order to give the motor control time to automatically reset so that it can restart the motor. Electrical power to your unit is controlled by the temperature control located in the front grille. (See Figure 9).

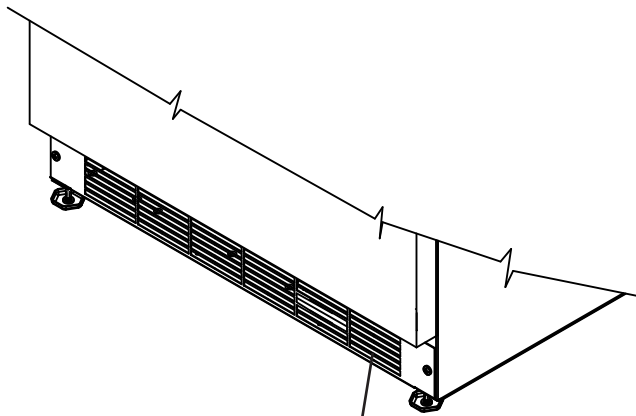

Figure 9

Temperature control located behind right side of air intake -exhaust grille.



Turn counterclockwise until it stops to shut off the compressor and fan.

DIMENSIONS FOR MODEL MS15FA SOLID DOOR

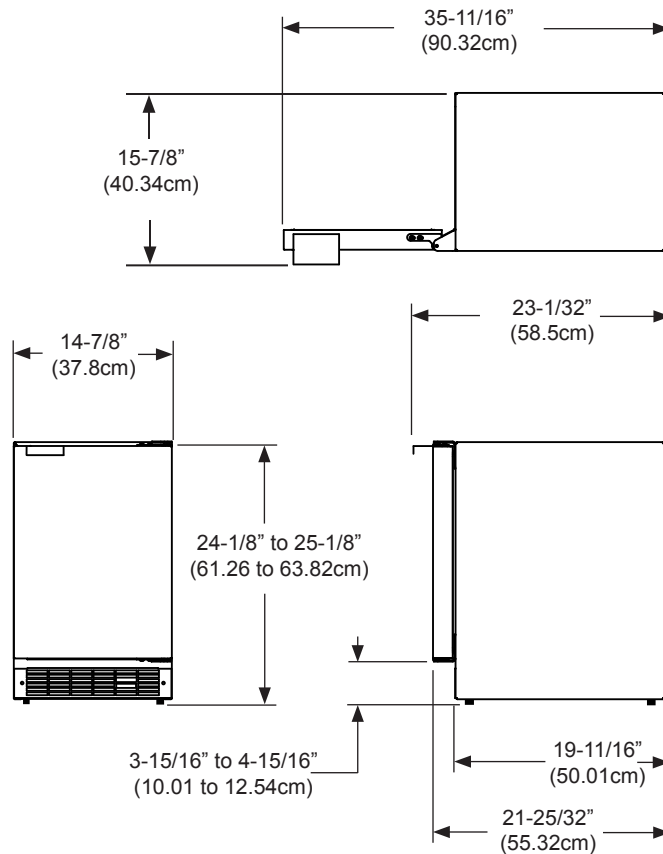

RECOMMENDED ROUGH IN OPENING DIMENSIONS, MS15FA SOLID DOOR

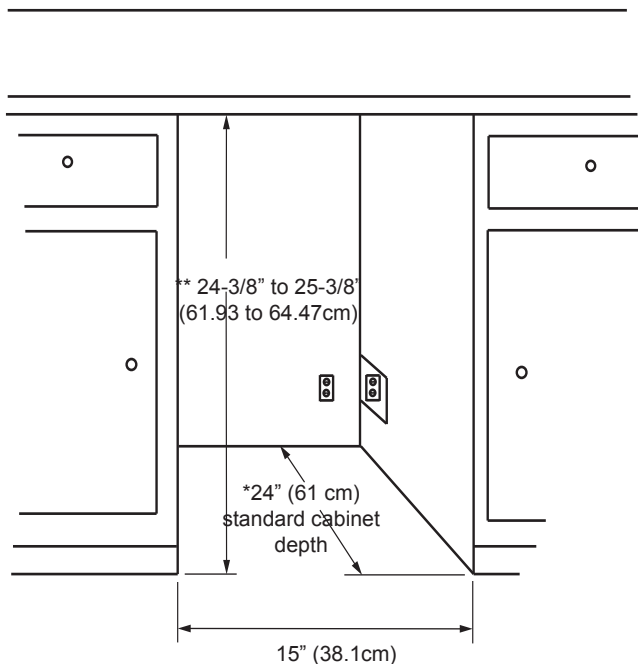

⚠ CAUTION

Electrical Requirements: A 115 volt, 15 amp dedicated circuit is required. A 3 prong grounded receptacle is required.

Power outlet can be located in the back wall behind unit. Add 1" to depth for thickness of plug, or recess outlet 1" into the wall. Power outlet can also be installed in adjacent cabinetry with a cutout for routing of power cord. Follow all local building codes when installing electrical and unit. Product weight = 70 lbs. (31.8 kg.)

* Depth dimension may vary depending on each individual installation.

** Minimum rough in opening required is to be larger than the adjusted height of the cabinet.

FEATURES AND ENERGY SAVING TIPS

MS15FA Features

Can be installed on the counter top or built in.

Temperature range = -4°C to -20°C.

Flat door liner.

Manual defrost.

Probe Port (optional) for MS15FA

The optional probe port is a hole from the inside to the outside of the unit, which could be located on the top, side, or back of the unit. After inserting your wires or probe, seal the hole tightly with caulk, putty, foam, etc. for proper operation.

Product Temperature versus Air Temperature

Air temperature moves up and down with door openings and compressor run and off cycles. Air has little thermal mass and therefore changes temperature relatively quickly as the unit cycles on and off. Stored products have thermal mass so their temperatures change much more slowly. While air temperature may change 5 to 10 degrees C between run and off cycles, stored product temperature typically changes less than 2 degrees C due to their thermal mass. Always measure product temperature, not air temperature, to determine if the products being stored are at the proper temperature.

Energy Saving Tips

The following suggestions will minimize the cost of operating your refrigeration appliance.

1. Do not install your appliance next to a hot appliance, (ovens, glassware washers, etc.) heating air duct, or other heat sources.
2. Install product out of direct sunlight.
3. Assure the toe grille vents at front of unit beneath door is not obstructed and kept clean to allow ventilation for the refrigeration system to expel heat.
4. Plug your appliance into a dedicated power circuit. (Not shared with other appliances).
5. When initially loading your new product, or whenever large quantities of warm contents are placed within refrigerated storage compartment, minimize door openings for the next 12 hours to allow contents to pull down to compartment set-point temperature.
6. Maintaining a relatively full storage compartment will require less appliance run time than an empty compartment.
7. Assure door closing is not obstructed by contents stored in your appliance.
8. Allow hot items to reach room temperature before placing in product.
9. Minimize door openings and duration of door openings.
10. Use the warmest temperature control set-point that provides the proper storage for your stored contents.
11. Set the control to the "off" position if cleaning the unit requires the door to be open for an extended period of time.
12. Annually clean condenser heat exchange coil located in machine compartment underneath unit, (see "Care and Cleaning" page 10).

CARE AND CLEANING

Condenser Air Flow

The condenser underneath the cabinet does not require frequent cleaning; however, satisfactory cooling depends on adequate ventilation over this heat exchanger. It is recommended to annually clean the condenser by vacuuming and brushing. To access the condenser, the unit must be pulled out from the installation, and the lower machine compartment access cover removed.

CAUTION

Disconnect the power cord before cleaning the condenser.

Be sure that nothing obstructs the required air flow openings in front of the cabinet. At least once or twice a year, brush or vacuum lint and dirt from the front grille area (see page 4).

Cabinet

The painted cabinet can be washed with either a mild soap and water and thoroughly rinsed with clear water. NEVER use abrasive scouring cleaners.

Interior

Wash interior compartment with mild soap and water. Do NOT use an abrasive cleaner, solvent, polish cleaner or undiluted detergent.

Care of Unit

1. Avoid leaning on the door, you may bend the door hinges or tip the unit.
2. Exercise caution when sweeping, vacuuming or mopping near the front of the unit. Damage to the grille can occur.
3. Periodically clean the interior of the unit as needed.
4. Periodically check and/or clean the front grille as needed.

Defrosting Instructions MS15FA

1. Disconnect the power cord and set the temperature control to the off position. (See page 7).
2. Remove the contents from the freezer.
3. Place pans of hot water in the freezer if you wish to speed up defrosting.
4. When defrosting is complete wipe out the interior and replace the contents.
5. Connect power cord to outlet.
6. Set the temperature control to the desired level.

WARNING

Do not use an ice pick, knife, or any type of sharp object to remove the ice. Doing so may puncture the units refrigerant system and damage it beyond repair. You may speed up defrosting by filling the ice bucket with hot water and placing it back into position.

TROUBLESHOOTING YOUR FREEZER

Before You Call for Service

If the unit appears to be malfunctioning, read through this manual first. If the problem persists, check the troubleshooting guide below. Locate the problem in the guide and refer to the cause and its remedy before calling for service. The problem may be something very simple that can be solved without a service call. However, it may be required to contact your dealer or a qualified service technician.

WARNING

Electrocution Hazard - Never attempt to repair or perform maintenance on the unit until the main electrical power has been disconnected. Turning the unit control "OFF" does not remove electrical power from the units wiring.

Problem	Possible Cause	Remedy
Unit too warm or too cold inside.	<ul style="list-style-type: none"> • Control set too warm or cold. • Airflow to front grille blocked. • Excessive usage or prolonged door openings. • Door gasket not sealing properly. 	<ul style="list-style-type: none"> • Adjust temperature colder or warmer as required. Allow 24 hours for temperature to stabilize. • Airflow must not be obstructed to front grille. See "clearances" on page 4. • Allow temperature to stabilize for at least 24 hours. • Check door alignment and/or adjust or replace door gasket.
Noise or Vibration.	<ul style="list-style-type: none"> • Unit not level. • Water line tubing vibration. 	<ul style="list-style-type: none"> • Level unit, see "Leveling Legs" on page 4. • Adjust the tubing as necessary to eliminate unwanted vibrations.
Unit will not run.	<ul style="list-style-type: none"> • Unit turned off. • Power cord not plugged in. • No power at outlet. 	<ul style="list-style-type: none"> • Turn unit on. See page 7. • Plug in power cord. • Check house circuit.
Moisture collects on outside surface of cabinet.	<ul style="list-style-type: none"> • Hot and humid conditions. 	<ul style="list-style-type: none"> • Extremely hot and humid conditions can cause condensation on outside of the cabinet. As humidity and/or temperature decreases, the condensation will disappear.
Moisture collects on inside of the unit.	<ul style="list-style-type: none"> • To many door openings. • Prolonged door openings. • Hot and humid conditions. 	<ul style="list-style-type: none"> • Limit the amount of door openings. • Limit the amount of time with the door open. • Extreme hot and humid conditions. Move unit to a controlled environment.

OBTAINING SERVICE

If Service is Required:

- If the product is within the first year warranty period please contact your dealer or call AGA MARVEL Customer Service at 800.223.3900 for directions on how to obtain warranty coverage in your area.
- If the product is outside the first year warranty period, AGA MARVEL Customer Service can provide recommendations of service centers in your area. A listing of authorized service centers is also available at www.agamarvel.com under the service and support section.
- In all correspondence regarding service, be sure to give the model number, serial number, and proof of purchase.
- Try to have information or description of nature of the problem, how long the unit has been running, the room temperature, and any additional information that may be helpful in quickly solving the problem.
- Table A is provided for recording pertinent information regarding your product for future reference.

For Your Records	
Date of Purchase	
Dealer's name	
Dealer's Address	
Dealer's City	
Dealer's State	
Dealer's Zip Code	
Appliance Serial Number	
Appliance Model Number	
Date Warranty Card Sent (Must be within 10 days of purchase).	

Table A

COMMERCIAL PRODUCT WARRANTY

Entire Product - One Year Parts and Labor Warranty

AGA MARVEL warrants to the original purchaser that it will supply all necessary parts and labor to repair or replace in the end user's establishment, any component which is found by an authorized representative of AGA MARVEL to be defective in materials or workmanship, subject to the conditions and exclusions stated below, for a period of one year from the date of purchase by the end user.

Refrigeration System - Additional Second Through Fifth Year Parts Only Warranty

During the four years following expiration of the one year limited warranty, AGA MARVEL warrants to the original purchaser that it will supply replacement parts for the hermetically sealed refrigeration system which consists of the compressor, evaporator, condenser, drier, and connecting tubing that are found to be defective in workmanship or materials. Other parts, labor costs, and freight charges are the responsibility of the end user.

If AGA MARVEL is unable to repair or replace the defective product or component, AGA MARVEL shall issue a credit to the buyer for all or part of the purchase price, as AGA MARVEL shall determine. The repair, replacement or payment in the manner described above shall be the sole and exclusive remedy of buyer for a breach of this warranty.

Buyer must give written notice of any alleged defect in the product to AGA MARVEL within 30 days after discovery of the defect by buyer. If notice is not given within such period, any claim for breach of warranty shall be conclusively deemed to have been waived, and AGA MARVEL shall not be liable under these warranties. AGA MARVEL or its agents shall be entitled to examine the product. AGA MARVEL shall have the option of requiring the return of the defective component, transportation prepaid, to establish the claim. The acceptance by AGA MARVEL of any component returned shall not be deemed an admission that the product is defective or in breach of any warranty and, if AGA MARVEL determines that the product is not defective, the component shall be re-shipped to the buyer at the buyer's expense. No component will be returned to AGA MARVEL without its prior consent.

The above warranties do not cover:

- Shipping costs of replacement parts or returned defective parts.
- Customer education or instructions on how to use the freezer.
- Any content loss, or incidental or consequential damage or loss due to product failure.
- Removal or installation.

Nor do the above warranties cover failure of this product or its components due to:

- Transportation, damage sustained in transit or subsequent damages.
- Use in hostile environments or use for storage of contents hostile to the product.
- Improper installation, misuse, abuse, accident or alteration, use on wiring not conforming to electrical codes, low voltages, failure to provide necessary maintenance, or other unreasonable use.
- Parts or service not supplied or designated by AGA MARVEL.

The above warranties also do not apply if:

- The original bill of sale, deliver date, or serial number cannot be verified.
- The refrigeration equipment is not in the possession of the original end use purchaser.

The warranties set forth herein are the only warranties extended by AGA MARVEL and are in lieu of all warranties, express, implied, statutory or otherwise. In particular, AGA MARVEL makes no warranty of merchantability or fitness for a particular purpose.

AGA MARVEL's liability for any defect in the product shall not exceed the purchase price of the product. **AGA MARVEL shall have no liability for consequential damages of any kind whatsoever, including, but not limited to, personal injury, property damage, lost profits or other economic injury due to any defect in the product.**

No person, firm, or corporation is authorized to modify, expand or extend these warranties, to waive any of the limitations or exclusions, or to make any other warranty or assume any other obligation for AGA MARVEL. These warranties apply only to products used in any of the fifty states of the United States and the District of Columbia.

To obtain performance of this warranty, report any defects to:

AGA MARVEL

1260 E. VanDeinse St.
Greenville MI 48838

Toll-Free: 800.223.3900



www.agamarvel.com

AGA MARVEL
1260 E. VanDeinse St.
Greenville MI 48838

800.223.3900

41014321-EN Rev C
3/29/18

All specifications and product designs subject to change without notice. Such revisions do not entitle the buyer to corresponding changes, improvements, additions, replacements or compensation for previously purchased products.